

MRS MACHINE PUMP-BACK STATIONS

THE FLEXIBLE ALTERNATIVE FOR CHIP- AND COOLANT HANDLING

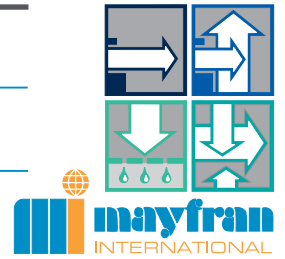

CHIPS AND COOLANT EASY CONVEYING...



MRS-D

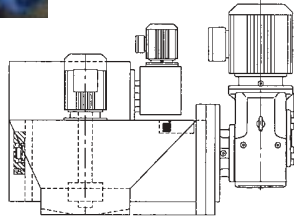

MRS-BP

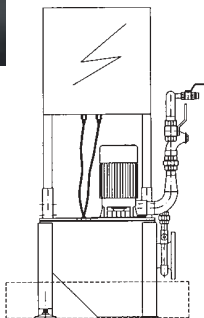

MRS-RC

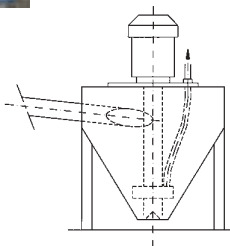

Machine pump back stations are easy to retrofit nearly to all types of machines. Chips and coolant (oil as well as emulsion) will be conveyed through pipes to a central filter or processing plant.



Central filter processing plant pumped by MRS pump back stations

Because of the flexible constructional style you can also connect single machines with a MRS. For example: to reclaim expensive oils.

For bushy type of chips the MRS can be extended with a crusher for pumping chips and coolant.

...REDUCE COOLANT COSTS



... the alternative to costly in-floor constructions

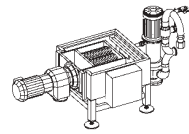
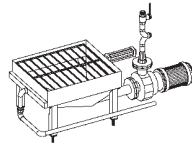
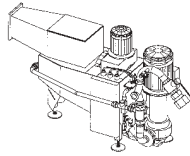

mayfran

amount of types

| | | Tank Dimensions mm | | | Type of operation | Capacity* l/min | |
|-------------|------------------------------|--------------------|-------|------------|------------------------|-------------------------|-----------|
| | | Height | Width | Length | | Oil | Emulsion |
| MRS-D | with drag conveyor | up 400 | from | variable | machine tools | 40 - 1100 | 40 - 1100 |
| MRS-RC | without conveyor | | 400 | 400 - 1000 | grinding | 45 - 600 | 90 - 1200 |
| MRS-BP | without conveyor | | to | 400 - 1000 | grinding | 45 - 600 | 90 - 1200 |
| MRS-S | with spiral conveyor | | 1000 | variable | machine tools | 35 - 780 | 70 - 1560 |
| MRS-Special | Custom required construction | | | | all types of operation | depends on requirements | |

All MRS-Types can be upgraded with a crusher or power screen classifier

* Capacities depend on type of coolant as well as type and quantity of chips



ADVANTAGES OF MRS PUMP BACK STATIONS:

- Easy change from single filter units to central coolant cleaning and supply
- No more expensive costly in-floor constructions
- Money saving because of low investment costs
- Flexibility of MRS is also guaranteed after relocation of machine tools
- Clean hall floors because of closed piping systems
- MRS can be individually designed for new machine tools

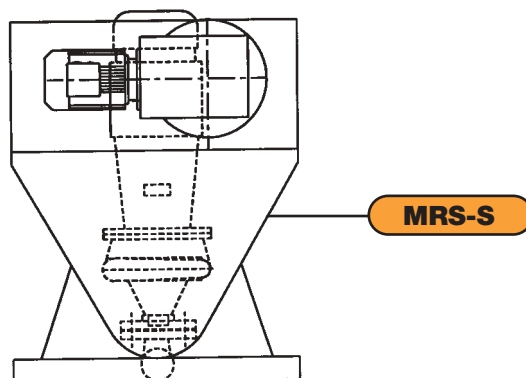

Examples for MRS-Special

Mayfran International B.V.

P.B. 31032, Edisonstraat 7
NL-6370 AA Landgraaf/The Netherlands

Tel.: 31-45-5329292
Fax: 31-45-5329300
E-mail: info@mayfran-europe.com



Mayfran U.K. Ltd., Orchard Court V

Binley Business Park, Harry Weston Road, Coventry CV3 2TQ
Tel.: 01203-459000, Fax: 01203-459690

Mayfran France S.A.R.L.

Centre D'Affaires, Paris-Nord, Immeuble le Bonaparte
F-93153 Le Blanc Mesnil Cedex/France
Tel.: 33-1-48-65-7800
Fax.: 33-1-48-67-7629

Mayfran GmbH, Roermonder Str. 594

D-52072 Aachen/Germany
Tel.: 49-241-938720, Fax: 49-241-175080
E-mail: sales@mayfran-europe.com

Mayfran International (Inc.)

P.O. Box 43038
Cleveland, OH 44143 /U.S.A.
Tel.: 1-440-461-4100
Fax: 1-440-461-5565
E-mail: info@mayfran.com

Tsubakimoto Mayfran Inc.

5001 Ohno, Tsuchiyama-Cho, Kouga-Gun
Shiga 528-02/Japan
Tel.: 81-7486-7-1001
Fax: 81-7486-7-1097

Mayfran Canada Ltd.

#26 - 83 Galaxy Blvd.
Toronto, ON M9W 5X6/Canada
Tel: 1-416-213-8111
Fax: 1-416-213-0005
sales@mayfran.ca

Miven Mayfran

P.O. Box 59 Karwar Road,
Hubli-580 024/India
Tel.: 91-836-303-677
Fax: 91-836-303-265

Korea Mayfran

72-1, Onsoo-dong
Kuro-ku 152-120, Seoul/Korea
Tel.: 82-2-611-5886
Fax: 82-2-686-2521