



TOTAL SCRAP CONTROL

SHUFFLE DRIVE CONVEYOR SYSTEMS
MAYFRAN INTERNATIONAL

QUALITY, BUILT IN.

Innovation in Motion
TSUBAKI

 **mayfran**
INTERNATIONAL

SIMPLE. ADAPTABLE. EFFECTIVE.

Mayfran International's Shuffle Drive Conveyor Systems offer patented simplicity, minimal maintenance and superior reliability for the most demanding industrial operations.

Proven to provide rapid payback and operational benefits for years to come, Mayfran's shuffle conveyors are engineered to meet your specific needs. They have been used for press-mounted scrap removal, crushers, lasers, spiral conveyors, offset tray systems and telescopic tray systems. **With flexible design parameters that can adapt to any situation, our systems can be used in a wide variety of applications and industries, including:**

- Material and scrap management
- Stamping
- Laser/Plasma cutting
- Solid waste and recycling
- C&D recycling
- Forging
- Die-casting
- Aggregates
- Food processing
- Pharmaceuticals

The shuffle conveyor is perfect for moving a variety of materials and types of scrap of all sizes, including:

- Laser scrap and fines
- Motor laminations
- Heavy die-casting components, such as transmissions
- Heavy steel bar offcuts
- Stamping scrap
- Construction and demolition waste
- Bulk material
- Turnings and chips



QUALITY, BUILT IN.

PERFORMANCE WHERE YOU NEED IT MOST

Features and Benefits

- Smooth operation, zero vibration
- Low-maintenance, solid-surface tray for problem-free conveying
- Designed for 24/7/365 “lights out” operation
- Energy-efficient operation
- Starts under full-load conditions
- Horizontal motion; gentle on product
- Tray shape can be specifically designed per customer application
- Systems on a single drive can handle tray lengths up to 350 feet long

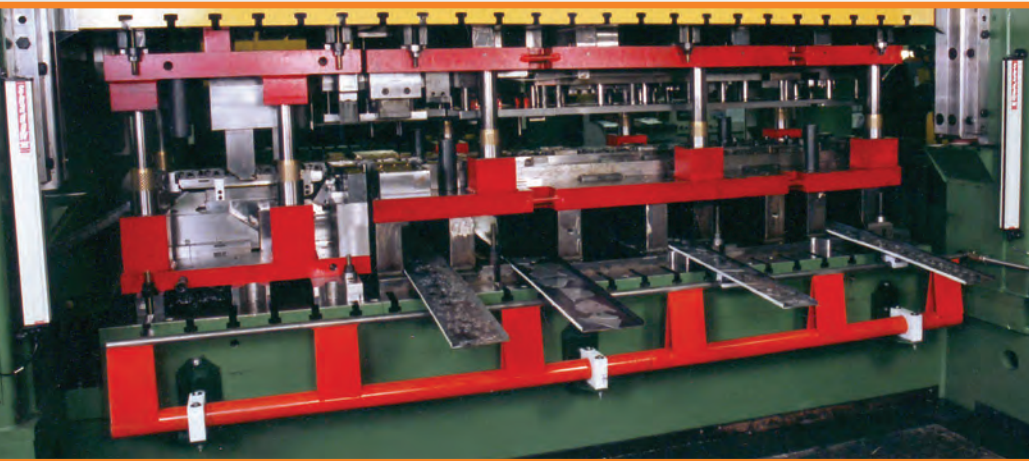

QUALITY, BUILT IN.

RAPID RETURN ON INVESTMENT

With Mayfran's shuffle conveyors, you can expect payback within just a few months. Get in touch with a Mayfran representative for the expected ROI for your specific operation.

Shown below are the typical savings from using a press-mounted shuffle drive system.

Utility cost savings

\$2,500/YEAR¹

Savings from increased uptime
because of reduced repairs

\$5,500/YEAR²

Savings through
reduced setup time

\$20,000/YEAR³

1 Using electricity vs. compressed air

2 Many air shakers require monthly repairs vs. shuffle drive conveyor maintenance-free operation

3 Value of increased press utilization from faster die changeovers

CONFIDENCE FOR EVERY APPLICATION

Press-Mounted Applications

- Designed to fit the smallest to the largest of presses
- No tools required for die changes
- Quiet compared to noisy air shakers
- Reduce shop air consumption
- All voltages made available
- Patented cross shaft allows for heavy off-center loading
- A complete press-mounted shuffle system can move up to 20,000 lbs/hour.

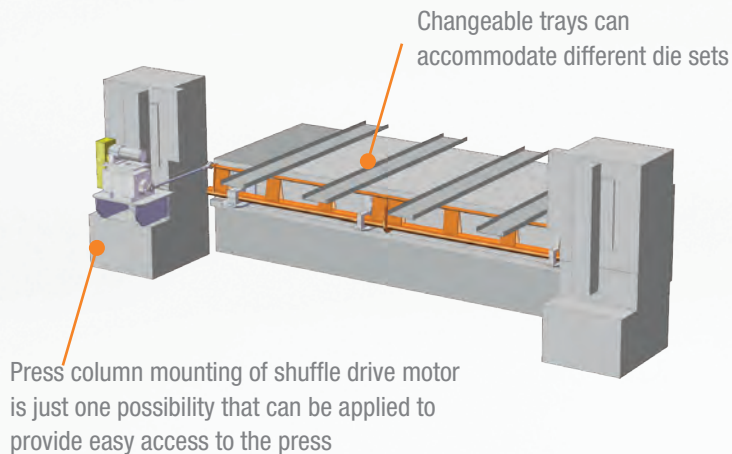

Laser/Plasma Cutting Applications

- Can be designed for use below the cutting area or in combination with the cutting area by being located under the exchange table
- Can be integrated into the machine design, floor-mounted or in the floor under the machine
- Optional heavy-duty elevating PolyArmor® conveyor to discharge the debris into a chip bin available
- Designed to fit most major laser OEM equipment
- No carryover of debris back into the machine
- No moving parts that encounter the abrasive laser-cut debris or fines mean increased conveyor uptime and reduced machine downtime

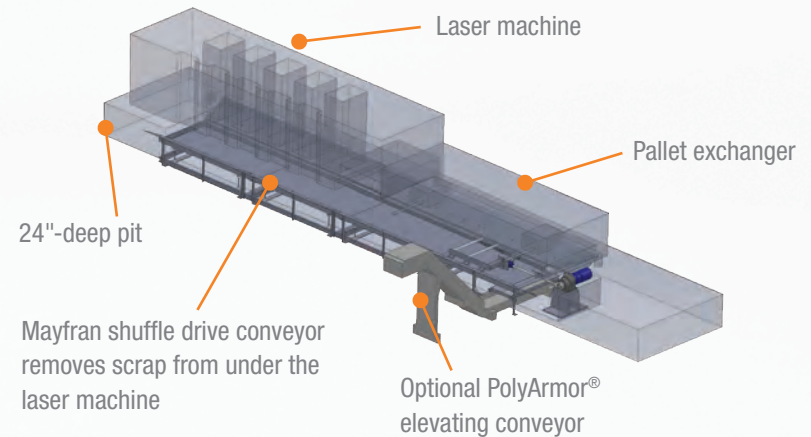

Mayfran steel belt conveyor provides
incline capability in integrated systems

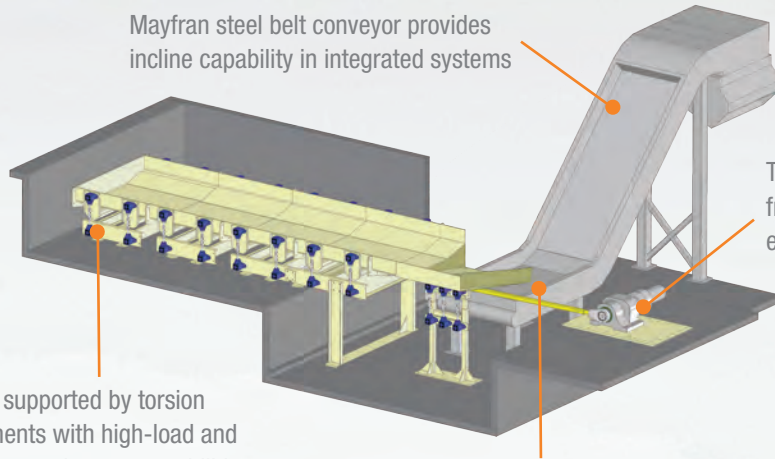

The drive is located away from the system where the environment is less harsh

Tray supported by torsion elements with high-load and impact-resistance capabilities

Connecting rod has self-aligning spherical bearings with grease fittings or auto-greasers (as determined by customer)

Material and Scrap Management

- Flexible design parameters available from gentle to high-impact, heavy-industry systems
- High-heat application systems available
- Flexible drive locations to suit customer needs
- Sealed watertight trays prevent press lubricant contamination



ABOUT MAYFRAN INTERNATIONAL

Mayfran is your single-source designer, manufacturer and project manager for any conveyor system need. We're here to help across markets in ways that are cost-effective, technologically advanced, operationally safe and environmentally responsible.

Founded in 1933, Mayfran is the world's leading manufacturer of specialized conveyor and processing systems for numerous global industries. Mayfran joined the Tsubakimoto Chain Group as a wholly owned subsidiary in 2012. Celebrating its 100th anniversary in 2017, Tsubakimoto Chain is the global leader in power transmission and materials handling with over 7,500 employees in 24 countries worldwide.



MAYFRAN AMERICA
PRT (Canada)

MAYFRAN LIMBURG
MAYFRAN GERMANY
MAYFRAN FRANCE
MAYFRAN UNITED KINGDOM
MAYFRAN CZECH REPUBLIC

TSUBAKIMOTO MAYFRAN
MIVEN MAYFRAN